

Bench Top Stand Assembly Instructions

See exploded diagram overleaf

1. BTS tube up with the adjustable locking handle at the top and facing you.
2. The back foot goes at the back of the post.
3. The front foot goes at the front of the BTS tube, under the adjustable locking handle.
4. Bolt the 2 feet to the post with the 2 M10x90mm bolts provided, from front to back.
5. Secure the bolts with the nuts and washers provided, on the back of the stand, the side with the back foot.
6. Tighten with a 16mm (5/8) spanner and an 8 mm (5/16) allen key.
7. Bolt the grinder to the tilt bracket with the 4 M10x25mm bolts, nuts and washers provided.

NOTE:

We recommend bolting the grinder to the Bench Top Stand before attaching the motor to the grinder.

The tilt stops located on the back of the post of the Bench Top Stand are adjustable by loosening the centre bolt with a 4mm (5/32") allen key and rotating them. This alters the horizontal and vertical positions of the grinder.

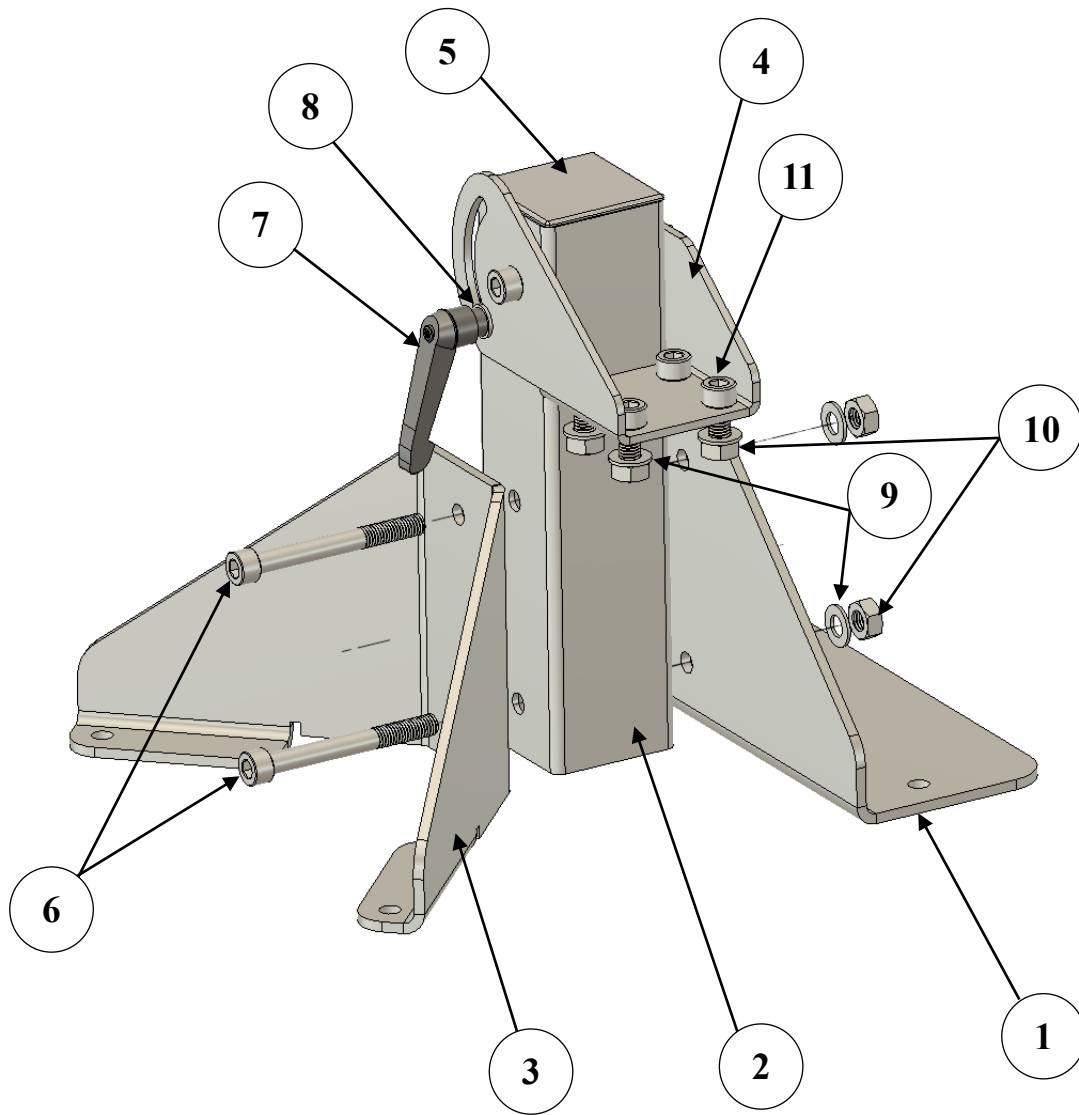

Item	Qty	Part Name
1	1	BTS Back Foot
2	1	BTS Tube
3	1	BTS Front Foot
4	1	Tilt Bracket
5	1	RHS Cap
6	3	M10x90 Socket Head Bolt
7	1	M8x20 Locking Handle
8	1	M8 Washer
9	6	M10 Washer
10	6	M10 Nut
11	4	M10x25 Socket Head Bolt